

**AUBE '01**  
12TH INTERNATIONAL  
**CONFERENCE ON AUTOMATIC  
FIRE DETECTION**

March 25 - 28, 2001  
National Institute Of Standards and Technology  
Gaithersburg, Maryland U.S.A.

**PROCEEDINGS**

Editors: Kellie Beall, William Grosshandler and Heinz Luck



**NIST**  
National Institute of Standards and Technology  
Technology Administration, U.S. Department of Commerce

*A. Freiling European Aeronautic Space and Defense Company EADS  
Airbus GmbH, Bremen, Germany*

***New approaches to Aircraft Fire Protection***

***Abstract***

Currently, new fire detection technologies are under evaluation for aircraft application. The goal is to reduce the false alarm rate drastically and to improve safety and reliability figures. Gas sensor technologies, visualization devices and other multi-sensor/multi-criteria are under discussion. In this paper, an overview of currently fire protected areas in Airbus aircraft is given. The potential to introduce specific fire protection by the means of new technologies in dedicated aircraft areas is discussed. If new fire detection technologies are used, there is the need to have modified integration tests. A comparison of a commonly used aircraft integration test to a real fire scenario is given by the example of a gas sensor based fire detector.

***Introduction***

A fire protection system in an aircraft includes passive and active fire protection means [1]. Passive fire protection is realized by using fire proof or inflammable materials in all areas of the aircraft including lining, cables, interior etc. In this paper, the active fire protection system will be regarded which consists of scattering light smoke detectors managed by a central control unit and a halon extinguishing system. Several aircraft areas are equipped with fire detection instruments. These are the cargo compartments, the electronic compartments and the lavatories. The most important and critical area is the cargo compartment, which is inaccessible during flight.

For ground based applications, which includes building fire protection, new kinds of fire detectors like multi-sensor/multi-criteria- or gas sensor based fire detectors have currently been developed or are under discussion [2, 3, 4, 5]. The main goal of using these kinds of sensors is to reduce the false alarm rate. Also the aircraft fire false alarm rate and the correlated consequences have to be reduced drastically [6, 7]. There are several restrictions and additional requirements that come along with the airborne application [8]. For new fire detection technology to be used in aircraft, there is the necessity to revise the integration / validation test. At EADS Airbus, new fire detection technologies are examined for aircraft application to improve the alarm reliability and to provide additional means for monitoring fire or smoke in dedicated aircraft areas.

### **Fire protected aircraft areas – state-of-the-art**

#### **A- Lavatories**

The fire protection of aircraft lavatories is realized by a scattering light smoke detector near the air extraction and an automatic fire extinguisher in the receptacle. In case of a fire alarm, the lavatory door can be opened and a crew member can extinguish the fire with a handheld fire extinguisher. Figure 1 shows a drawing of a lavatory and installation points of smoke detectors.

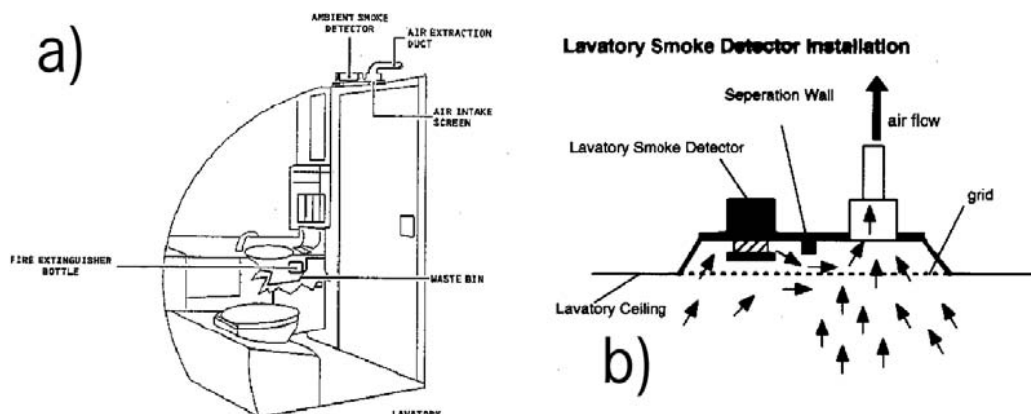

Fig. 1: a) Sketch of an aircraft lavatory, b) Installation of a lavatory smoke detector in Airbus

## **B- Avionics Compartment**

In the avionics compartment, nearly all the electronics necessary to fly the aircraft is located. Commonly, the compartment is positioned under the cockpit, in the front part of the aircraft. In most aircraft, the avionics compartment is not accessible during flight. Only in larger Airbus aircraft, there is a small access hatch. The compartment is ventilated, with the extracted air passing through a common air extraction duct which is monitored for the presence of smoke.

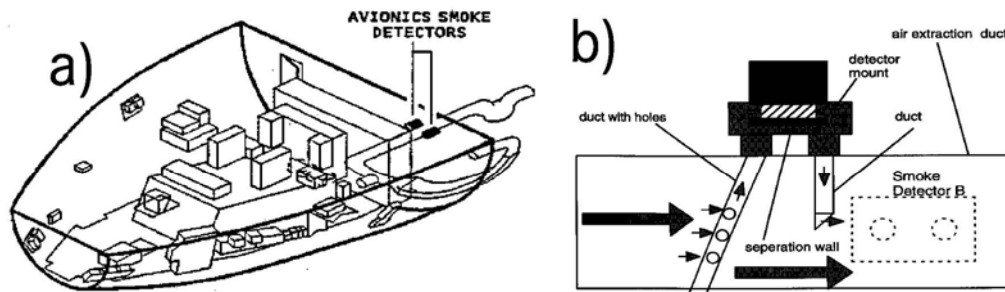

Fig. 2: a) Sketch of an aircraft avionics compartment, b) Installation of duct type smoke detector in Airbus

## **C- Cargo Compartments**

More critical areas in the aircraft in which smoke detectors are installed, are the cargo compartments. In transport aircraft, these compartments are normally located under the actual passenger cabin, the forward (FWD) compartment in front and the aft compartment behind the wing box. During flight, the cargo compartments are inaccessible. That means that in case of a fire warning, the pilot has got no possibility to verify

if it is a real or a false alarm. The action the pilot has to take after a fire warning is to activate the extinguishing system and to land as soon as possible, eventually on an unsuitable airport [9]. A further reason for a high risk within the cargo compartment is that the freight cannot be controlled by the aircraft manufacturer. Although there are restrictions on what is allowed to be transported, there is still the possibility that dangerous ignition sources get into the aircraft.

Concerning fire extinguishing, there fire extinguishing bottles installed in transport aircraft. As extinguishing agent, halon is used. Although halon is generally banned by the Montreal Protocol, there is a time limited exceptional regulation and it can still be used for aircraft application. This regulation expires in 2003. Until then, alternatives have to be found.

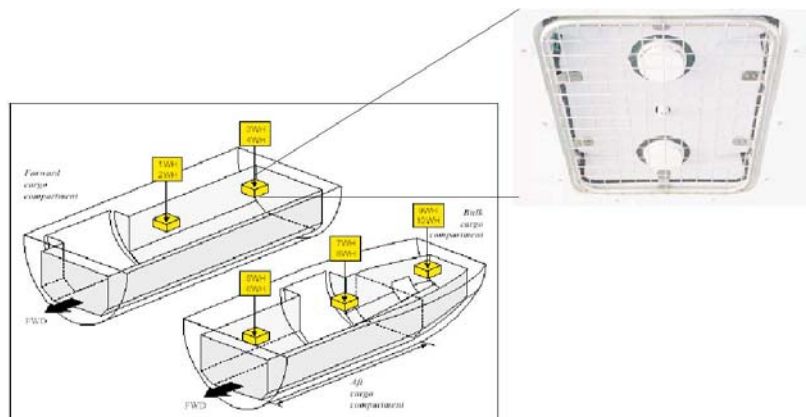

Fig. 3: Airbus Cargo Compartment Smoke Detector Positions and installation

### **D- Lower Deck Facilities**

With the development and construction of larger aircraft, there comes the wish to use additional space gained in the lower deck. In order to accommodate more passengers in the main deck area, certain facilities will be located in the lower deck area of the aircraft. These are galleys, toilets, crew rest areas (with beds for the passengers/crew to sleep), etc. Along with

the installation of such facilities, there comes the necessity to install fire detection.

### **State-of-the-art aircraft fire detection technology**

The signal processing of the scattering light type smoke detectors currently applied in the Airbus aircraft series uses specifically developed smoke discrimination algorithms. Using specific light frequencies, modulations and correlation in the time domain with a database allows differentiating between typical smoke patterns. The overall aircraft smoke detection system consists of the smoke detectors at several locations (see section 2) and the so-called Smoke Detection Control Unit (SDCU) which controls and reads out the detectors. A block diagram of the system architecture is given in Fig. 4. For redundancy reasons, the smoke detectors in the cargo compartment and in the avionics compartment are installed in pairs. Each pair of detectors is supplied with power by a dual redundant power supply (see Fig. 4). One detector in the pair is installed on the Smoke Detection Control Unit (SDCU) loop A, the other on loop B. The SDCU tests each loop to check whether it is functioning before it acts on a smoke alarm from a single smoke detector. When a smoke alarm is generated by the SDCU the ventilation and heating systems (if installed) will be closed automatically.

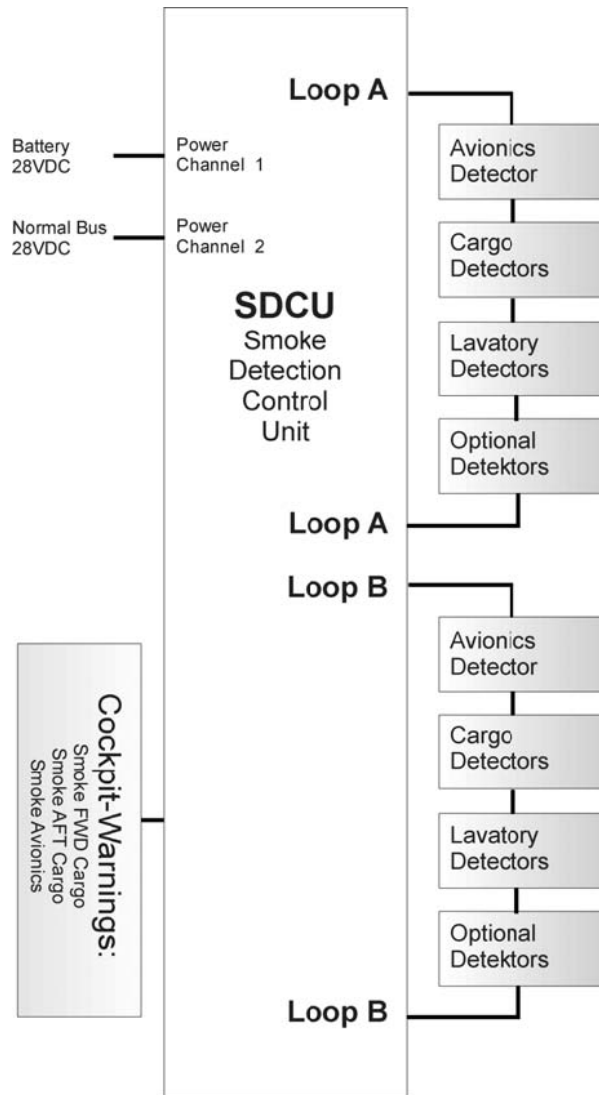

Fig. 4. Smoke Detection Loop Schematic for A340

### Approaches to new kinds of fire detection

Currently under investigation are advanced fire detection technologies with the aim to identify the proper fire signatures (gas, smoke, heat etc.) as they may develop in a crucial, inaccessible area of the aircraft and develop the algorithms which allow to link these fire parameters to non-fire events that may be present in the aircraft. Technology under consideration to reach adequate detection properties includes [10]:

- Gas sensing with semi-conducting metal oxide sensors in thick- or thin-

- film technology or/and electrochemical cells
- Optical smoke sensing with light attenuation or back-scattering devices
  - Near infra-red (NIR, wavelengths  $< 1.2\mu\text{m}$ ) and visible light sensing with CCD (Charge Coupled Device) and/or CMOS (Complementary Metal Oxide Semiconductor) technology
  - Infra-red sensing with thermopiles (for wavelengths  $> 1.2\mu\text{m}$ )

It is possible to subdivide several aircraft areas to dedicated fire sectors with dedicated fire protection systems. One example for that can be a special fire protection of avionics compartments where the materials that can burn are relatively well defined. So, may be the possibility to develop a system based on gas sensors that detects smoldering cable fires or overheated equipment. A certain spatial resolution in fire detection would give the pilot a decision means of what measures to take if an area of the electronics compartment becomes overheated. If the heat source is an uncritical item, then this equipment can easily be switched off. In the Cargo compartment, where the kind of material that might burn is unpredictable, the approach is different. Here, there is the necessity to know the non-fire case in order to reduce false warnings. So far, it has never happened in Airbus aircraft that a fire was undetected when a smoke detection system was installed. The problems are false alarms caused by cargo. To improve the false alarm rate, knowledge about environmental conditions in false alarm cases is necessary. Therefore, database studies have been conducted in order to get as much information as possible about these conditions. The results are presented elsewhere [11].

### **Approaches to new fire extinguishing methods and dedicated fire detection**

Water mist as halon replacement in combination with nitrogen inerting is regarded as a promising alternative to the today's extinguishing system. The use of a water mist system however implies several physical-chemical aspects which could have been neglected with gaseous systems but now have



to be checked and solved. Agent freezing, short circuit prevention, weight, maintenance or smoke generations are points which have to be considered. For weight and efficiency reasons, the water mist suppression system must be associated to a smart detection/activation system which is able to accurately detect and locate the fire and activate the suppression in adequate on/off sequences. There are several requirements for the detection system that are derived from a water mist based extinguishing system. In order to carry only a minimum amount of water in the aircraft due to weight reasons, the extinguishing process has to be optimized. An extinguishing shall only be performed where the fire is located. This implies that the fire detection system must be able to provide a certain spatial resolution. At the moment, there is no need for such a zonal detection system because the halon extinguishing system is based on a total flood philosophy. Furthermore, the detection system has to be waterproof because it has to monitor the fire criticality status for the total remaining flight. The extinguishing efficiency of water, even in combination with an inert gas is not comparable to the properties of halon and there is a remaining risk that the fire will light up again. So, a fire monitoring function is necessary. The research concerning these items is being funded by the European Commission within the 5th Framework Program FireDetEx.

### *Aircraft integration of new fire detection technologies*

After qualifying fire/smoke detectors for aircraft application, they have to be implemented / integrated into the aircraft environment. Current integration tests for smoke detectors are defined in the FAA Advisory Circular 25-9A [12]. The integration tests mentioned herein can be performed with appropriate smoke generators, being selected out of the following list, depending on the actual installation point of the sensor:

- paper towel burn box
- Rosco Theatrical smoke generator
- Helium-injected Rosco Theatrical smoke generator
- A pipe or cigar
- A Woodsman Bee Smoker
- Any other acceptable smoke generator The smoke emerging from one of those sources must be detected within one minute after the start of the fire [13]. This time includes all the necessary signal processing and transduction to display an alarm message in the cockpit.

### *Consequences for new technologies*

The existing authority requirements concerning integration of smoke detectors restrict the development of new approaches. An example are multi-criteria/multi-sensor devices. Such a system needs a certain time to process a certain internal signal evaluation out of the various parameters that are

recorded to come to an alarm decision. This alarm decision will be of a higher reliability, but might take a little more time. Furthermore, the event “start of a fire” is not clearly defined. The amount of smoke produced for example by a smoke generator might be equal to the smoke emitted in a rather advanced state of a real fire.

Although other parameters that represent a real fire are not reflected by an artificial smoke generator. This includes heat release in terms of radiation and convection as well as gas development. Current developments show that gas sensing technologies have a potential to be new or additional fire detectors. At the moment, there is no integration test that is could be used for certification of such a system. A real fire test as described in AC 25-9A cannot be conducted during flight. But only a real fire has the gas constitution that is detected by gas sensors. Fig. 5 shows a test that has been conducted to compare the response of gas sensors to a currently used smoke generator in Airbus (AX1000) and a real fire of Kleenex tissue towels. The test was carried out in a standard-layout lavatory. As sensing device a GSME smoldering fire detector as it is used for lignite power plants was examined [14]. This device comprises 3 semi-conducting metal oxide gas sensors with optimized selectivity for H<sub>2</sub>, CO and NO<sub>x</sub>. The GSME detector and its signal processing algorithm had not been modified for this test. First, the smoke generator was switched on, producing an amount of smoke labeled equal to 5 Kleenex tissue paper towels. It can be seen that the gas sensor device responds very poorly with all its 3 sensors and shows a slightly decreasing signal. The aircraft optical smoke detector which was also installed reacted after 35 seconds. The GSME was positioned near the basin, which means it was not installed where the current detector is installed. By burning 3 Kleenex, the detector showed a significant signal and the internal processing algorithm predicted a certain “fire probability” which can be used for defining an alarm threshold. Not being on its proper position yet and burning 5 Kleenex resulted in a higher signal but a similar fire probability. Afterwards, the sensor was installed into the position of the current detector and again, 5 Kleenex were burned. This time, the signal shape looked different due to

changed airflow conditions the sensor was exposed to and the fire probability had a higher value. The final two peaks are two cycles of cigarette smoke, the first just normally smoking and the second smoking and blowing at the detector. Cigarette smoke shows a different signal shape than Kleenex towels and it can be seen that cigarette smoke does not result in any value for the fire probability.

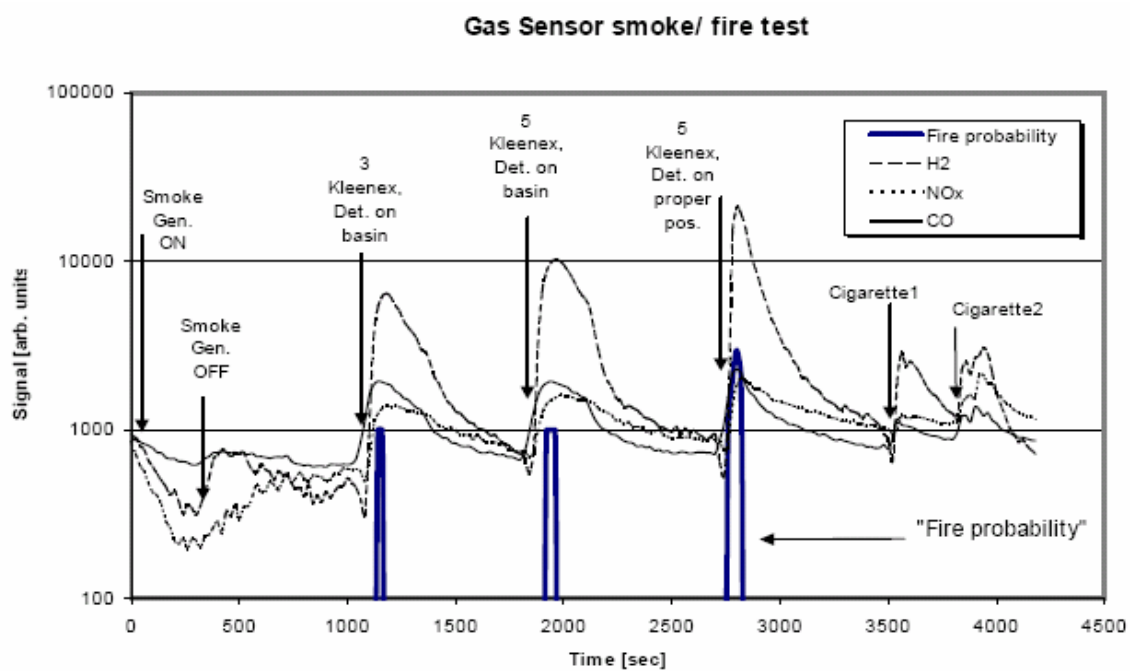

Fig. 5: Comparison of a smoke detector test with a real fire for a gas sensor based fire detection system

This example shows that the common smoke generator integration test is not suitable for this kind of fire detector because these types of gas sensors will never respond to this specific kind of smoke. Only if the gas constitution of a characteristic fire is known, a gas generator might be constructed for assuring a correct integration. But in this case, all the other fire parameters will not be regarded. In this context it becomes clear, that new detection technologies need dedicated specific-to-type aircraft integration flight tests

after they have proven their fire detection properties in ground tests.

### **Summary**

New fire detection technologies bear the potential to improve the safety of aircraft by making a fire warning more reliable and by reducing the false alarm rate. The risk of unnecessary passenger evacuations and undue emergency landings can be minimized that way. Approaches are the use of gas sensors or other multi-sensor/multi-criteria devices as well as visualization tools like specific cameras with associated image processing. However, the way to aircraft integration coincides with the fulfillment of stringent environmental and many other aircraft specific requirements. The technology that is used for fire detection instruments strongly influences the kind of testing that is necessary to validate a proper integration. For this reason the user of new fire detection instruments, in this case the aircraft manufacturing industry, has to know exactly what technology is used inside a fire detector in order to perform the right verification for demonstration of compliance with the certification requirements.

## Literature

- [1] Freiling, A. Brandschutz in Airbus-Flugzeugen, S&S Report, April 2000
- [2] Gottuk, D.T., Peatross, M.J., Roby, R.J., and Beyler, C.L., "Advanced Fire Detection Using Multi-signature Alarm Algorithms," International Conference on Automatic Fire Detection "AUBE '99", 11th, March 16-18, 1999, Gerhard Mercator University, Duisburg, Germany, Luck, H., Editor, pp. 237-246, 1999.
- [3] Petig, H et al. History of Development Steps in Gas Sensor Fire Detection in RWE Powerplants for Lignite and Waste Combustion, International Conference on Automatic Fire Detection "AUBE '99", 11th, March 16-18, 1999, Gerhard Mercator University, Duisburg, Germany, Luck, H., Editor, pp. 284-294, 1999.
- [4] Müller, H.C. Rule based Detection Algorithms, Proceedings of the VdS Conference "Gas Sensors for Fire Detection", Nov. 15<sup>th</sup> and 16<sup>th</sup> 2000, Cologne, Germany, Chairing: Michael Schnell, VdS Schadenverhütung
- [5] Siebel, R. Strategies for the development of detection algorithms, Proceedings of the VdS Conference "Gas Sensors for Fire Detection", Nov. 15<sup>th</sup> and 16<sup>th</sup> 2000, Cologne, Germany, Chairing: Michael Schnell, VdS Schadenverhütung
- [6] Blake, D. Aircraft Cargo Compartment Fire Detection, International Halon Replacement Working Group Meeting, May 2000, Atlantic Hotel, Bremen, Germany, hosted by EADS Airbus GmbH
- [7] Grosshandler, W.L. (Editor), Nuisance Alarms in Aircraft Cargo Areas and Critical Telecommunication Systems: Proceedings of the Third NIST Fire Detector Workshop, December 4-5, 1997, NISTIR 6146, National Institute of Standards and Technology, Gaithersburg, MD, March 1998
- [8] Freiling, A. Requirements for Fire Detection in Civil Aviation,

- Proceedings of the VdS Conference “Gas Sensors for Fire Detection”,  
Nov. 15<sup>th</sup> and 16<sup>th</sup> 2000, Cologne, Germany, Chairing: Michael Schnell,  
VdS Schadenverhütung
- [9] Schmötzer, K, Aircraft Fire Detection Requirements, see see this book  
of conference
- [10] Freiling, A, Improving Safety for Aircraft, Proceedings of the Deutscher  
Luft- und Raumfahrtkongress 2000, ref. DGLR-JT2000-156, Sept. 16-20  
2000, Leipzig, Germany, Deutsche Gesellschaft für Luft- und Raumfahrt
- [11] Mangon, P. Fire Detection for aircraft cargo compartments, reduction of  
false alarms, see this book of conference
- [12] Federal Aviation Administration, Advisory Circular 25-9A, Smoke  
Detection, Penetration and Evacuation Tests and related Flight Manual  
Emergency Procedures, 1/6/94, Federal Aviation Administration,  
Washington DC, USA
- [13] Joint Aviation Requirements, JAR-25, Large Aeroplanes, Change 14,  
27May 1994, JAA, Hoofddorp, The Netherlands
- [14] Kohl, D, Kelleter, J. Gassensor-Melder für Schwelbrände, in:  
Sicherstellung der Schutzfunktion von Gassensoren, A. Freiling, R.  
Fromm, Edts. pp. 154-165, Beuth-Verlag, Berlin, ISBN 3-410-79234-1,  
Dec. 1997